

# CO2 Monitor Operating Instructions

Model: ZG10U

Table of Contents

1. Product Instruction
2. Package Content Check & Main Unit View
3. LCD Display Symbol
4. SEU (Sensor Unit) Function Instruction
5. RDU (Remote Display Unit) Function Instruction
6. Safety Notes
7. Caring For Product
8. Installation Instruction
9. Customizing Settings
10. CO2 & Temperature Specification
11. Weight & Dimension
12. Fault Codes & Troubleshooting Guide

## 1. Product Instruction

Thank you for selecting the ZG10U CO2 Monitor. It is designed to detect the presence of Carbon Dioxide in the ambient air to protect people in confined spaces. High concentrations of CO2 in confined spaces are dangerous, and may lead to health problems ranging from headaches and fatigue to asphyxiation and death. The ZG10U CO2 Monitor is with the audible alarm and visual indication which will activate when CO2 concentration reaches a pre-set level. Detection of high levels of CO2 will also activate a relay that could be used for a fan to ventilate the confined space and reduce CO2 concentration in the area. The ZG10U CO2 Monitor can be widely used in CO2 storage areas, breweries, wineries, cellars, beverage dispensing areas, and fast food outlets.

ZG10U CO2 Monitor is cost-effective and has many features:

1. NDIR (Non-Dispersive Infrared) technology is used to measure CO2 concentration up to 50,000 ppm (parts per million).
2. With the SEU (Sensor Unit) and RDU (Remote Display Unit), it can connect up to 3 RDU for safety notices.
3. Large digital LCD display clearly indicates the ambient CO2 concentration and temperature.
4. Relay output can automatically control a fan to ventilate confined spaces.
5. Audible and visual alarm indications.
6. IP54 Water Proof Protection of SEU( Sensor Unit) except backside when installed on the wall

## 2. Package Content Check & Main Unit View

The ZG10U package comprises the following parts:

Main Unit:

SEU( Sensor Unit)	RDU (Remote Display Unit)	Panel holders
Network cable connector	7 meters communication cable	User manual

Accessories:

Plug lock	1 pc	Screw	10pcs	Expansion plug	10 pcs
Nail cable clip	10 pcs	Warning paper	1 pc		

Caution: please take off the rubber cap and put it to the position L when ZG10U is taken from the package, the vents is not blocked while ZG10U is working.

## SEU (Sensor Unit)

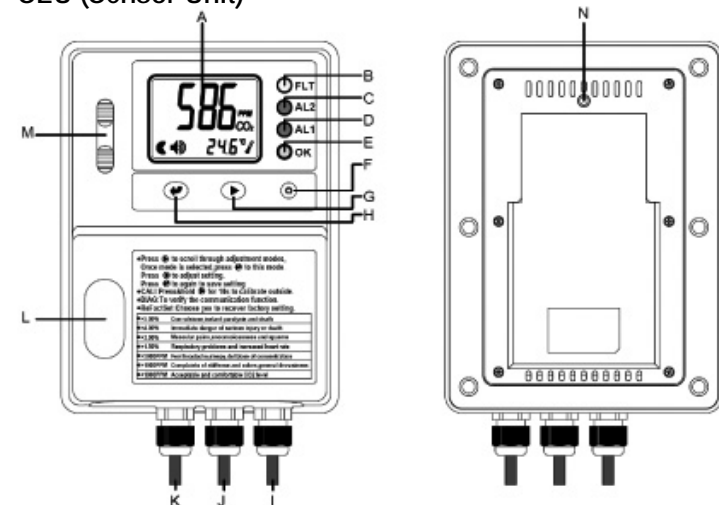

- A. LCD display
- B. Yellow LED( Fault indication)
- C. Red 2 LED(AL2)
- D.Red 1 LED(AL1)
- E. Green LED (Power indication)
- F. Reset Button
- G. Mode Button
- H. Enter Button
- I. Communication Cable to RDU
- J. Relay output
- K. Power Supply
- L. Rubber Cap
- M. Gas entry
- N. Buzzer

## RDU (Remote Display Unit)

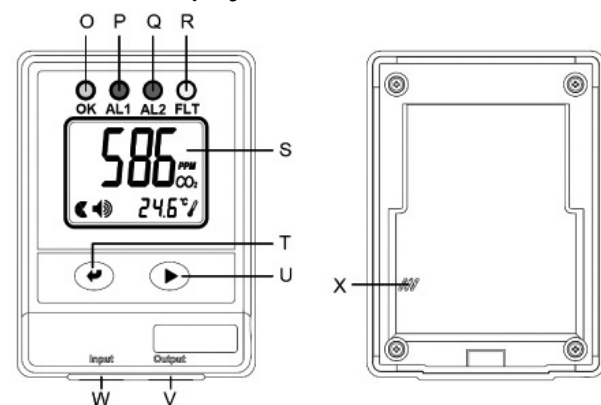

- O. Green LED(Power indication)
- P. Red 1 LED (AL1)
- Q. Red 2 LED (AL2)
- R. Yellow LED ( Fault indication)
- S. LCD display
- T. Enter Button
- U. Mode Button
- V. RJ45 Plug for next RDU (Output)
- W. RJ45 Plug for SEU( Input)
- X. Buzzer

## 3. LCD Display Symbol

Symbol	Meaning	Description
586 ppm CO2	CO2 Concentration ppm (Parts Per Million)	ambient CO2 concentration
24.6°C	Temperature (Celsius)	ambient temperature in Celsius
76.3°F	Temperature (Fahrenheit)	ambient temperature in Fahrenheit
🔊	Alarm	alarm icon
DIAG	Diagnose	Test communications between the SEU and RDU
AL1	First Alarm level	The relay will be triggered when CO2 concentration exceeds the first alarm level, the Red 1 LED will flash, and buzzer will sound
AL2	Second Alarm level	Safety Notice "ESC" displays on LCD when CO2 concentration exceeds the second alarm level. The Red 1& Red 2 LEDs will flash, and buzzer will sound
CALI	Calibration	To calibrate the CO2 sensor when the accuracy deviates from the actual CO2 concentration.
ReFactSet	Recover Factory Setting	To recover factory default settings and cancel any customized settings
ESC	ESC	To indicate the CO2 leakage once the CO2 level is above the second alarm level
Hi	Hi	The CO2 concentration is above 5%.

## 4. SEU (Sensor Unit) Function Instruction

The SEU (Sensor Unit) should be placed in a room where the CO2 is likely to accumulate, such as a room where CO2 is stored, like an area with CO2 beverages. The large LCD displays the ambient CO2 concentration and the temperature.

The SEU has the "DIAG", "AL1", "AL2", "CALI", "ReFactSet" function. The "DIAG" function executes communication tests between the SEU and RDU. The user can do the calibration under the "CALI" mode when necessary. If data-setting is done incorrectly, the user can use the "ReFactSet" back to the original factory setting.

There have "AL1" "AL2" two alarm levels, the alarm level is adjustable, the first alarm level is with parameter 0.5%, 1%, 1.5%, 2%, the default first alarm level is 1.5%. The second alarm level is with parameter 1.5%, 2%, 2.5%, 3%, 3.5%, 4%, the default second alarm level is 3%.

When the ZG10U CO2 Monitor detects CO2 concentration that exceeds the first alarm level, the red 1 LED will blink and the buzzer will sound intermittently, the relay will be triggered. When CO2 concentration drops the first alarm level, the red 1 LED will stop blinking and buzzer will stop beeping.

If the concentration of CO2 continues to rise above the second alarm level, the red 1 and red 2 LED's will flash together and the tempo of the buzzer will increase. When CO2 concentration drops below the second alarm level, even to the first alarm level, the red 1 and red 2 LED's will remain blinking, and the buzzer will remain beeping. Unless the ZG10U is restarted, by means of reset button of ZG10U or unplug the AC adapter and reconnected it.

The green LED will light continuously when the power is normally supplied.

Warning: If the ambient CO2 concentration reaches the second alarm level, on SEU & RDU, there will be a safety notice "ESC" displays on the LCD, Careful action, such as ventilating the space, must be taken before entering the room where the SEU is placed.

To clear the flashing "ESC" from the LCD, use the "ReFactSet" to restore the unit to the original factory settings, or unplug the AC adapter and reconnect it to the power.

If the communication cable between the SEU & RDU doesn't connect well, like the communication cable looses in the Input port, the fault LED of SEU will blink, reconnect the cable, if the cable is inserted into the output port, on RDU, after °C/°F flashing one minute, the "Er7" will flash on LCD. Unplug the cable and plug it into the Input port. The unit will work normally after corrective action.

If cleaning places where the SEU is installed, first take off rubber cap off and putting it on the position of gas entry. Water will not enter into the SEU during cleaning. The following picture shows the position changes of the rubber cap.

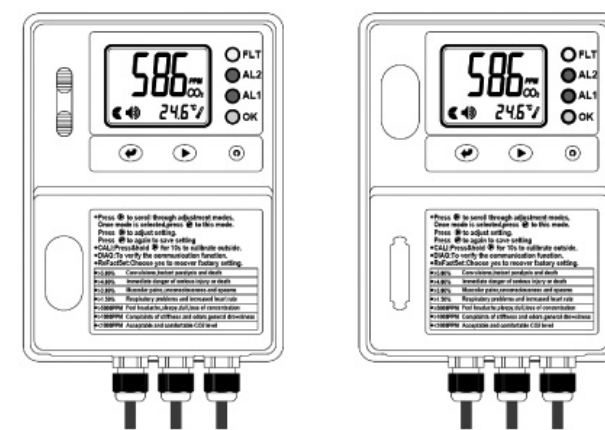

## 5. RDU (Remote Display Unit) Function Instruction

The RDU (Remote Display Unit) should be placed outside the room when in use. The RDU is connected to the SEU with a wire that has a maximum length of 25 feet. The RDU should be placed where it can be conveniently observed before entering the room where the SEU is located. The RDU is a repeater, and displays the measurements made by the SEU on an easy-to-read digital LCD along with important safety information.

The RDU has "DIAG" function. The "DIAG" can test the communication between the SEU and RDU. Resetting the ZG10U CO2 Monitor is only available from SEU.

## 6. Safety Notes

Warning: Your safety is very important to us. To ensure to use the product correctly and safety, please read these warnings and the entire User Manual before using the product. Otherwise, the protection provided by the equipment may be impaired.

These warnings provide important safety information and should be observed at all times.

1. Please handle the device carefully; do not subject the product to impact or shock.
2. Do not place the unit, or the adaptor near a heat source. Heat can cause distortion of the unit, which may result in an explosion or fire.
3. Do not touch the exposed electronic circuitry of the device under any circumstances, as there is the dangerous of electric shocks.
4. Please use only the included power adaptor. Improper power adaptor or power sources can cause serious damage to the product, or result in injury or death to the user.
5. Please use the "DIAG" function to verify the communication between SEU and RDU, to make sure the communication between SEU and RDU works normally.
6. Please make sure that the power adaptor is mounted by plug lock tightly, so the power adapter can not be disconnected without using of mechanical tools.
7. Do not enter into the room directly if there has safety notice "ESC" displays on the LCD of SEU & RDU. Some careful and protective action must be taken before entering the room where the SEU is installed.
8. Please take care of cable connection between SEU and RDU. Make sure the cable from SEU is connected into the INPUT port of RDU.
9. Please ensure the external power supply is normally supplied to ventilation fan while the relay is working. If there has no normally power supply to the fan, the relay will not work, which may result in potential danger with high CO2 concentration in confined space.

## 7. Caring For Product

To make sure to receive the maximum benefit from using this product, please observe the follow guidelines.

1. Repair - Do not attempt to repair the product or modify the circuitry by yourself. Please contact your local dealer or a qualified repairman if the product needs servicing.
2. Cleaning - Disconnect the power before cleaning. Use a damp cloth. Do not use liquid cleaning agents such as benzene, thinner or aerosols, as these will damage the device.
3. Maintenance - We recommend users to test the communication between the SEU and RDU under "DIAG" function to verify the working conditions for the SEU and RDU. If the four LED's blink and the buzzer of SEU and RDU sound simultaneously, it indicates that SEU and RDU work normally. When the LCD displays a safety icon "ESC", please take immediate protective action to check if CO2 leakage has occurred. We suggest users to do the calibration and thorough function check once within two year to make sure that the ZG10U CO2 Monitor is working properly.

## 8. Installation Instructions

Please carefully take out the SEU (Sensor Unit), RDU (Remote Display Unit), panel holders, network cable connector, 7 meters communication cable, user manual, plug lock, screws, expansion plugs, nail cable clips, warning paper from the package.

Step-by-Step Installation:

1. Choose a suitable location to install the SEU. Fix the panel holder on the wall with the four screws (included); the recommend installation height is about 0.45 meters (1.5 feet) from floor and close to the manifolds and valves as possible.
2. Put the SEU on the panel holder, making sure that they are connected tightly.
3. Fix another panel holder in a suitable location outside the monitored space with screws (included). Push the RDU onto panel holder, and stick the warning paper next to RDU.
4. The communication cable is pre-wired to the SEU. Route the cable to the RDU and fixed the communication cable to the wall by nail cable clips, and then plug the cable into the input port on the RDU. Communication is now ready between the SEU and RDU.
5. The ZG10U CO2 Monitor has one relay output. The relay cable is pre-wired to SEU. The relay can control a fan or blower to ventilate the monitored space when necessary. The relay will be triggered when the CO2 concentration exceeds the first alarm level.
6. After finishing the installation, Connected the AC power adapter into the electrical supply outlet. Mount the Plug lock by expansion plugs so that the power adapter cannot be disconnected without use of mechanical tools.
7. When the power has been connected, The SEU and the RDU will begin to work. Please use the "DIAG" function to verify the communication between SEU and

RDU, the four LED's will blink and buzzer will sound on SEU & RDU., after that the communication is ready, the content of display is same on SEU & RDU.

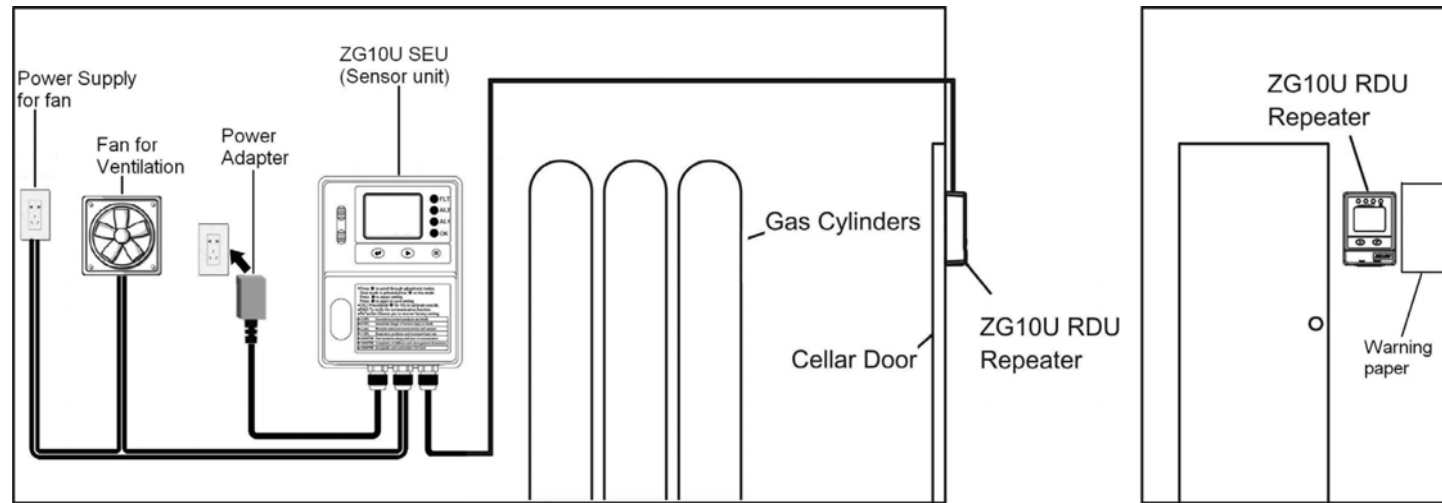

Mount the plug lock

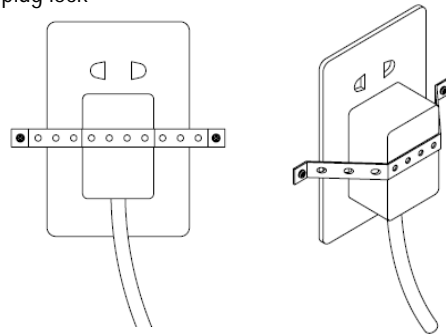

## 9. Customizing Settings

When power has been connected, the SEU and RDU will begin to monitor the CO2 concentration and the temperature. In order to get the timely alarm safety information and meet the personal requirements, It is advisable to set up the customizing parameter when necessary.

Temperature °C/°F:

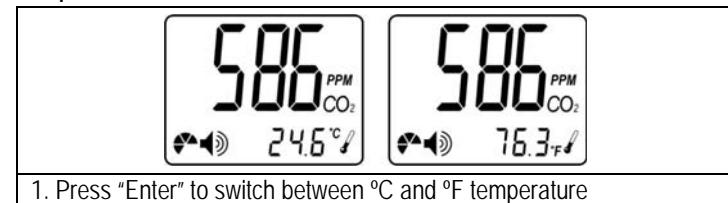

1. Press "Enter" to switch between °C and °F temperature

Using the DIAG function:

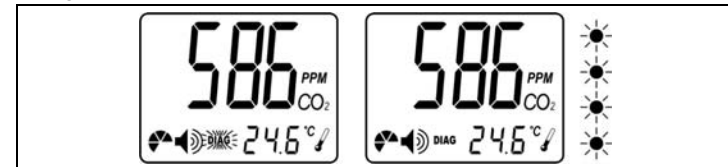

1. Press Mode until the "DIAG" icon flashes
2. Press Enter, the four LED's will blink on the SEU and the buzzer will sound
3. The four LED's will blink and buzzer will sound simultaneously on the RDU

Setting the First Alarm parameter:

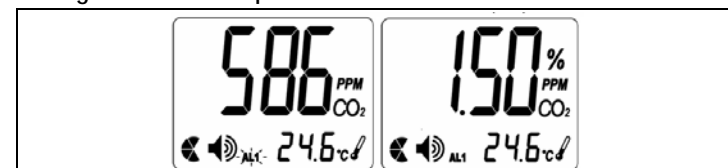

1. Press Mode until the "AL1" icon flashes
2. Press Enter, the "AL1" icon shows on LCD
3. Press Mode to go through "0.5%, 1%, 1.5%, 2%" alarm level
4. Press Enter again to save the setting after selection

Setting the Second Alarm parameter:

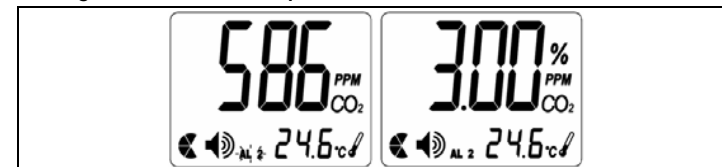

1. Press Mode until the "AL2" icon flashes
2. Press Enter, the "AL2" icon shows on LCD
3. Press Mode to go through "1.5%, 2%, 2.5%, 3%, 3.5%, 4%" alarm level
4. Press Enter again to save the setting after selection

Notes: The second alarm level should be higher than the first alarm level when setting with the alarm level parameter.

Using the CALI function:

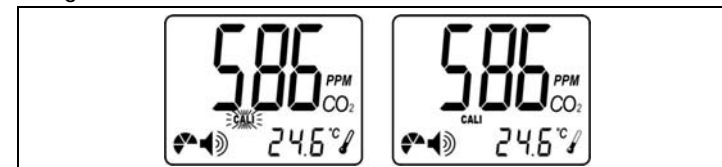

1. Press Mode until the "CALI" icon flashes
2. Press Enter, the "CALI" icon shows on the LCD
3. Press and hold Mode for at least 10 seconds. The "CALIBRATING" icon will flash. The calibration will be done automatically. After 10 minutes the LCD will display "Pass" or "Fail". If "Fail", please try again.

Notes: When do the calibration, it is suggested to take SEU outside, using the ambient gas for calibration, waiting around 10 minutes until the CO2 reading of SEU doesn't change, then use the 380-420 ppm as the standard CO2 reading. Calibrating the unit according to "CALI" mode instruction, user should not breathe toward to SEU during the calibration process, as the CO2 from the user will affect the CO2 reading of SEU.

Using the ReFactSet function:



1. Press Mode until the "ReFactSet" icon flashes
2. Press Enter, and then press Mode to choose either "Yes" or "No"
3. Press Enter again to save the setting after selecting

Note: If the user sets the data or calibrates the sensor incorrectly, use the ReFactSet (recover the factory Setting) to come back the default factory setting.

## 10. Specification

CO2 & Temperature specification:

CO2 Specification	
Measurement Range	0 - 50,000 ppm (5%) display
Display Resolution	10 ppm
Accuracy	±100 ppm or ±5% of reading, whichever is greater
Repeatability	±20 ppm @400 ppm
Annual Drift	<20 ppm/Year@400ppm
Temperature Dependence	±0.2% of reading per °C or ±2 ppm per °C, whichever is greater, referenced to 25°C
Pressure Dependence	0.13% of reading per mm Hg
Response Time	<60 seconds for 90% response to step change
AL1 (First Alarm Level)	0.5 / 1 / 1.5 / 2 %, Default AL1= 1.5%
AL2 (Second Alarm Level)	1.5 / 2 / 2.5 / 3 / 3.5 / 4 %, Default AL2= 3%
Sound Alarm	80db@10cm
Warm-Up Time	<60 seconds at 22°C

Temperature Specification:

Temperature Range	0°C to 50°C (32°F to 122°F)
Display Resolution	0.1°C (0.1°F)
Display Options	°C/°F
Accuracy	±1°C(±2°F) when CO2 concentration is below first alarm level
Response Time	20-30 minutes (case must equalize with environment)
<b>Operating Conditions:</b>	
Operating Temperature	0°C to 40°C ( 32°F to 104°F)
Humidity Range	0 ~ 95% RH non-condensing
<b>Storage Conditions:</b>	
Storage Temperature	-20°C to 60 °C (-4°F to 140°F)

Power Supply & Relay Output:

Power Supply	AC adapter 110/220 VAC	
AC Input	Voltage	100 ~ 240 VAC
	Frequency	50 / 60 Hz
	Power Requirement	1 W maximum @ 115 VAC 60 Hz 2 W maximum @ 230 VAC 50 Hz
AC/DC Output	Voltage	6VDC
	Power	1.8 W
Peak Input Current	0.3 A from 6 VDC	
Relay Output	30 VDC or 250 VAC, max 2A, SPST, Normally Open	

## 11. Weight & Dimension

Weight: SEU (Sensor Unit): 459 g  
RDU (Remote Display Unit): 130 g

Dimension:  
SEU (Sensor Unit)

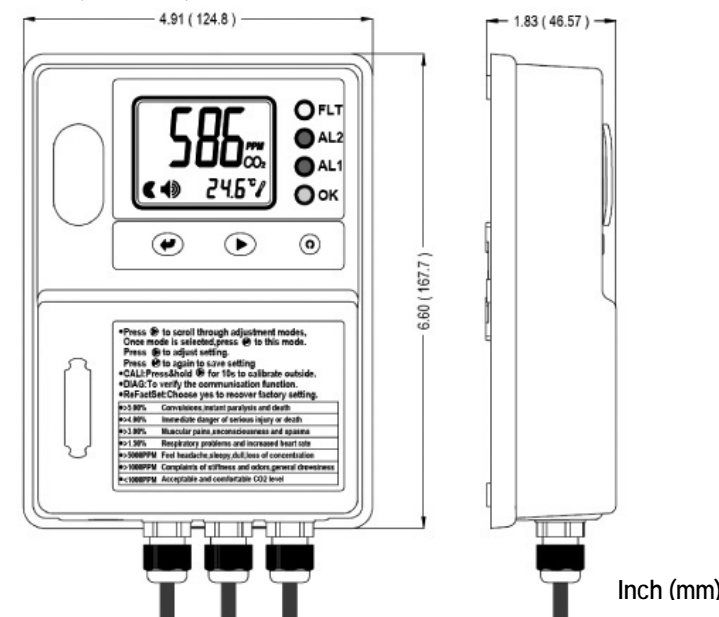

RDU (Remote Display Unit)

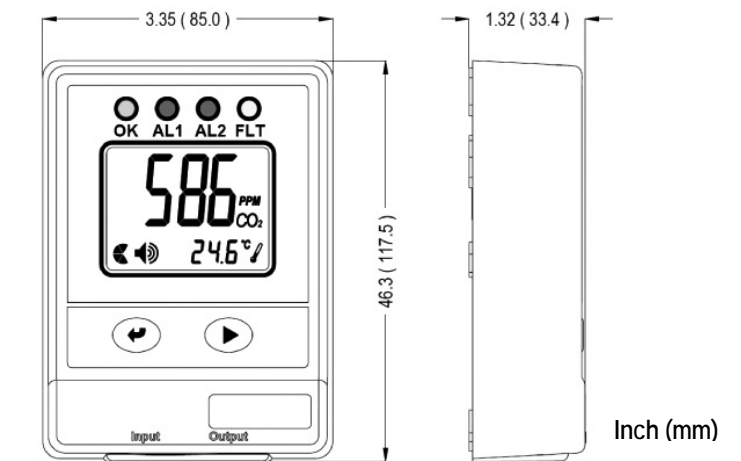

## 12. Fault Codes & Troubleshooting Guide

This section includes a list of Frequently Asked Questions for problems you may encounter with the ZG10U CO2 Monitor.

No	LCD Fault Icon	Description (of the fault)	SEU Indication	RDU Indication	Suggested Actions
1	Er3	The ambient temperature has exceeded the temperature range 0°C to 50°C ( 32°F to 122°F)	"Er3" flash Fault LED blink, Buzzer beep	"Er3" flash Fault LED blink, Buzzer beep	This error will disappear when the temperature returns to the range between 0°C and 50°C ( 32°F to 122°F)
2	Er4	some wrong measurement or the sensor has exceeded its expected life	"Er4" flash Fault LED blink, Buzzer beep	"Er7" flash Fault LED blink, Buzzer beep	Please unplug the AC adapter and reconnect it. If the "Er4" always appears, please contact with the local dealer.
3	Er5 Er6	EEPROM System Problem	"Er5" & "Er6" flash, Fault LED blink, Buzzer beep	"Er7" flash Fault LED blink, Buzzer beep	Please unplug the AC adapter and reconnect it. If the "Er5,Er6" always appear, please contact with the local dealer.
4	Er7	Internal Data Transmission Error	"Er7" flash, Fault LED blink, Buzzer beep	"Er7" flash, Fault LED blink, Buzzer beep	①Please unplug the AC adapter and reconnected it. ②Check the RJ45 plug is connected into the INPUT port of RDU,if the "Er7" displays on the RDU only.
5	Er8	The accuracy of CO2 sensor may deviate from the actual CO2 concentration.	"Er8" flash Fault LED blink, Buzzer beep	"Er8" flash Fault LED blink, Buzzer beep	①Please unplug the AC adapter and reconnect it If the "Er8" still appears, please contact with the local dealer. ②Please calibrate the unit, after the calibration, If the "Er8" still appears, please contact with the local dealer.

ZyAura  
Monitoring the invisible

Radiant Innovation Inc. [Http://www.ZyAura.com](http://www.ZyAura.com)  
1F, No.3, Industrial East 9th Road, Science-Based Industrial Park, HsinChu, Taiwan 300.



Ref.No. : 032011